



**CHILDREN'S SERVICES COUNCIL
OF BROWARD COUNTY
MEMBERS:**

*Jeffrey S. Wood, Chair
Governor Appointee*

*Beam Furr, Vice Chair
Broward County Commission*

*Dr. Christine Thompson, Secretary
Governor Appointee*

*Alyssa Foganholi
Governor Appointee*

*Debra Hixon
Board Member
Broward County Public Schools*

*Dr. Howard Hepburn
Superintendent
Broward County Public Schools*

*Julia Musella
Governor Appointee*

*Robert Shea
Child Protection Director,
Southeast & Southern Regions
Department of Children & Families*

*Dr. Paula Thaqi
Director
Broward County Health Dept.*

*Honorable Francis Viamontes
Judicial Member*

*Vacant
Governor Appointee*

STAFF

*Cindy J. Arenberg Seltzer
President/CEO*

LEGAL COUNSEL

*John Milledge
Garry Johnson*

DATE: October 11, 2024
TO: Council Members
FROM: Cindy Arenberg Seltzer, President/CEO
SUBJECT: Information for the October 17th Council Meeting

Happily, thanks to Hurricane Milton sparing our area, enclosed is the information packet for the CSC monthly meeting on Thursday, October 17th, from 9:30am-Noon, at the CSC Office. As a cost-saving measure, the meeting packet tabs are 22-31 and E-H. If you usually receive a hard copy packet via courier, it should arrive Friday afternoon.

Included in your action items is the draft 2025 monthly meeting schedule (Tab 24). The draft schedule maintains the traditional third Thursday morning of each month, but I draw your attention to the deviation from that in the months of June and September. Please cross-check all dates with your calendar and let us know if you have any scheduling conflicts, as we will need to ensure we have a quorum for all meetings.

This month's Roundtable will feature a presentation on the upcoming HEAL Trauma Request for Proposals (RFP). Members will have the opportunity to learn more about CSC's history in this area and shape its future direction.

If you have any questions or concerns about any of the items on consent, please feel free to email (cseltzer@cscbroward.org) or call me (954-649-8420) prior to the meeting.

I look forward to seeing you on the 17th!

Children's Services Council of Broward County Monthly Meeting
6600 W. Commercial Blvd., Lauderhill, FL 33319 (with Zoom access)

Thursday, October 17, 2024
9:30 a.m.

MEETING AGENDA

- I. Call to Order** Jeffrey S. Wood, *Chair*
- II. Roll Call** Amy Jacques, *Special Assistant*
- III. Chair's Report** Jeffrey S. Wood, *Chair*
- a. Moment to Arrive
 - b. Approve TRIM Minutes (9/26/24) **(Tab 22)**
 - c. Approve Council Minutes (9/26/24) **(Tab 23)**
 - d. Approve Cancelling Dec 2024 Meeting
 - e. Approve 2025 Meeting Schedule **(Tab 24)**
 - f. FYI – November Annual Report Photo
- IV. President's Report** Cindy Arenberg Seltzer, *President/CEO*
Good of the Order
- V. Chief Innovation Officer Report** Sue Gallagher, *CIO*
- a. Approve Urban League of Broward County **(Tab 25)**
as the Fiscal Sponsor for A Little Help
Never Hurts and Related Fees
 - b. FYI – Community Participatory Action **(Tab 26)**
Research Arts Exhibition Recap
 - c. FYI – Broward Consent Management **(Tab 27)**
Initiative
- VI. Chief Public Affairs Officer Report** Sharetta Remikie, *CPAO*
- a. Approve Acceptance of Revenue and **(Tab 28)**
Reconciliation of Expenditures for
Back-to-School Extravaganza FY 23/24
 - b. Approve the Purchase of Local Author **(Tab 29)**
Books for Family Literacy Event
- VII. Chief Operating Officer Report** David H. Kenton, *COO*
- a. Approve Budget Carryforward for **(Tab 30)**
Selected POs and Initiatives
 - b. Approve Disposal of Fully Depreciated or **(Tab 31)**
Non-Capitalized Items for FY 23/24

- c. Accept Managed Fund Monthly Statements **(Tab E)**
- d. Approve Monthly Purchases **(Tab F)**

- VIII. Broward Reads Coalition Meeting Report** Beam Furr, *Coalition Co-Chair*
- IX. Funders Forum Report** **(Tab G)** Maria Juarez, *CPO*
- X. Public Comment** Jeffrey S. Wood, *Chair*
- XI. Council Members' Roundtable**
HEAL Trauma RFP Visioning Lisa Bayne,
Director of Program Services
Brooke Sherman,
Sr. Programs Manager
Tabitha Bush,
Sr. Programs Manager
Kandyss Torrence,
Training Manager
Shira Fowlkes,
Sr. Planning & Research Manager
Florence Ukpai,
Research & Evaluation Manager
- XII. For Your Information** **(Tab H)**
- a. CSB Minutes
 - b. Community Impact
 - c. Attendance Report

Please complete this form <https://bit.ly/3nbSwe9> for ASL interpreter requests. For all other requests for special accommodations, please reach out to Betty Dominguez at (954) 377-1665 or bdominguez@cscbroward.org at least one week in advance so that proper arrangements can be made.

TAB 22

CHILDREN'S SERVICES COUNCIL OF BROWARD COUNTY

Truth In Millage (T.R.I.M.) Final Public Hearing

Held @ 6600 W. Commercial Blvd., Lauderhill, FL 33319
and by Zoom Webinar with public access by computer or phone

September 26, 2024

5:01 P.M.

Minutes

Members in Attendance:

Governor Appointee Alyssa Foganholi, Broward County Commissioner Beam Furr, School Superintendent Howard Hepburn, Governor Appointee Julia Musella, Health Department Director Paula Thaqi, Judge Francis Viamontes, Governor Appointee Jeffrey S. Wood (*Chair*)

Members in Virtual Attendance:

DCF Community Development Administrator Robert Shea

Council Members Absent:

School Board Member Debra Hixon, Governor Appointee Christine Thompson

Counsel Present:

Garry Johnson, Esq.

Staff in Attendance:

Cindy Arenberg Seltzer (President/CEO), Sharetta Remikie, Maria Juarez, Michelle Hamilton, Sue Gallagher, Dion Smith, Lisa Bayne, Kathleen Campbell, Kenneth King, Marissa Greif-Hackett, Marlando Christie, Amy Jacques, Marissa Aquino, Tracy Graham, Andria Dewson, Johnsingh Jeyasingh, Diego Alvarez, Jessica Rincon, Jennifer Wennberg, Meg Wallace, Nelson Giraldo, Akil Edwards, Jill Denis-Lay, Liza Khan, Jennifer Fletcher, Julie Toscano, Shawanda Spencer, Camila Mathieson, Keyonia Lawson, Latora Steel, Radoika Pilarte, Zinajen De Oliveira, Maxine Goldson, Michelle Hagues, Melissa Soza, Travis Johnson, Tabitha Bush, Jonathan Corado, Trisha Hines, Trisha Dowell, Ileana Blanco, Carlos Campos, Erin Byrne, Kandyss Torrence, Erica Ansley, Jocelin Eubanks, Nancy Adjohan, Yolanda Meadows, Lynn Kalmes, Brooke Sherman, Florence Ukpai, Zoe Lewis, Fern Phillip, Cristina Castellanos, S. Lorenzo Benaine, Roxanne Smith, Ivy Pierre, Amber Gross, Natalie Gomes, Madeline Jones, Pooja Yajnik, Alexia Bridges, Gaby Carbonell, Cynthia Reynoso, Maya Berryhill-Porter, Shaquoia Wilson, Priscilla Cole, Valencia McConnico-Bell, Nicolette Picardi, Ashley Brooks

Guests in Virtual Attendance:

Elizabeth Dorante (*Hispanic Unity of Florida*), Alison Bregman-Rodriguez (*YMCA of South Florida*), Jarvis Brunson (*Change Me Foundation Inc.*), Traci Schweitzer (*Department of Children & Families*), Cyndi Barry (*Harmony Development Center*), Kimberly Adams (*none listed*), Alice-Lydia Bird (*YMCA of South Florida*), Donna Lavalley (*Smith Community Mental Health*)

Agenda:

I. Millage Hearing

CSC Chair Jeffrey S. Wood called to order at 5:01 P.M. the final public hearing on the final millage rate and final budget for Fiscal Year 2024-2025.

The roll was called and a quorum was established.

Mr. Wood opened the public hearing for adoption of the final millage rate for FY 2024-2025. He read the tentative millage rate of 0.4500. Said millage rate is a 7.04% increase over the rolled-back rate.

Attorney Garry Johnson read Resolution 2024-03 by title only.

Mr. Wood opened the floor for comments from the public regarding the final millage rate. Hearing none, he closed the public comment period and opened the floor for comments from Council members. Vice Mayor Furr praised staff for a good job.

ACTION: Vice Mayor Furr made a motion to adopt the Resolution adopting the tentative millage rate of 0.4500 for Fiscal Year 2024-2025. The motion was seconded by Dr. Hepburn. A roll call vote was conducted, and the motion passed unanimously.

Council Member	Vote
Alyssa Foganholi	Yes
Beam Furr	Yes
Howard Hepburn	Yes
Debra Hixon	Absent
Julia Musella	Yes
Robert Shea	Yes
Paula Thaqi	Yes
Christine Thompson	Absent
Francis Viamontes	Prohibited from voting on millage rate, per statute
Jeffrey S. Wood	Yes

II. Budget Hearing

Mr. Wood opened the public hearing for adoption of the final budget for Fiscal Year 2024-2025.

Attorney Garry Johnson read Resolution 2024-04, by title only, adopting the final budget for Fiscal Year 2024-2025.

Mr. Wood opened the floor for comments from the public regarding the final budget. Hearing none, he closed the public comment period and opened the floor for comments from Council Members. Vice Mayor Furr praised staff for a good job.

ACTION: Dr. Thaqi made a motion to adopt the Resolution adopting the final budget for Fiscal Year 2024-2025. The motion was seconded by Vice Mayor Furr. A roll call vote was conducted and the motion passed unanimously.

Council Member	Vote
Alyssa Foganholi	Yes
Beam Furr	Yes
Howard Hepburn	Yes
Debra Hixon	Absent
Julia Musella	Yes
Robert Shea	Yes
Paula Thaqi	Yes
Christine Thompson	Absent
Francis Viamontes	Yes
Jeffrey S. Wood	Yes

III. Adjournment

The meeting adjourned at 5:05 P.M. with a motion from Vice Mayor Furr and a second from Dr. Hepburn.

Dr. Christine Thompson, Secretary

TAB 23

CHILDREN'S SERVICES COUNCIL OF BROWARD COUNTY

Held @ 6600 W. Commercial Blvd., Lauderdale, FL 33319
and by Zoom Webinar with public access by computer or phone

September 26, 2024

4:00 P.M.

Minutes

Council Members in Physical Attendance:

Governor Appointee Alyssa Foganholi, Broward County Commissioner Beam Furr, School Superintendent Howard Hepburn, Governor Appointee Julia Musella, Health Department Director Paula Thaqi, Judge Francis Viamontes, Governor Appointee Jeffrey S. Wood (*Chair*)

Council Members Absent:

DCF Child Protection Director Robert Shea, School Board Member Debra Hixon, Governor Appointee Christine Thompson

Counsel Present:

Garry Johnson, Esq.

Staff in Attendance:

Cindy Arenberg Seltzer (President/CEO), Sharetta Remikie, Maria Juarez, Michelle Hamilton, Sue Gallagher, Dion Smith, Lisa Bayne, Kathleen Campbell, Kenneth King, Marissa Greif-Hackett, Marlando Christie, Amy Jacques, Marissa Aquino, Tracy Graham, Andria Dewson, Johnsingh Jeyasingh, Diego Alvarez, Jessica Rincon, Jennifer Wennberg, Meg Wallace, Nelson Giraldo, Akil Edwards, Jill Denis-Lay, Liza Khan, Jennifer Fletcher, Julie Toscano, Shawanda Spencer, Camila Mathieson, Keyonia Lawson, Latora Steel, Radoika Pilarte, Zinajen De Oliveira, Maxine Goldson, Michelle Hagues, Melissa Soza, Travis Johnson, Tabitha Bush, Jonathan Corado, Trisha Hines, Trisha Dowell, Ileana Blanco, Carlos Campos, Erin Byrne, Kandyss Torrence, Erica Ansley, Jocelin Eubanks, Nancy Adjohan, Yolanda Meadows, Lynn Kalmes, Brooke Sherman, Florence Ukpai, Zoe Lewis, Fern Phillip, Cristina Castellanos, S. Lorenzo Benaine, Roxanne Smith, Ivy Pierre, Amber Gross, Natalie Gomes, Madeline Jones, Pooja Yajnik, Alexia Bridges, Gaby Carbonell, Cynthia Reynoso, Maya Berryhill-Porter, Shaquoia Wilson, Priscilla Cole, Valencia McConnico-Bell, Nicolette Picardi, Ashley Brooks

Guests in Attendance:

See Attachment 1

Agenda:

I. Call to Order

Mr. Wood called the meeting to order at 4:02 P.M.

II. Roll Call

The roll was called and a quorum was established.

III. Chair's Report

a) Moment to Arrive

Council Members took a moment to allow the body and mind to settle and focus before considering the meeting agenda items.

Mr. Wood made it known that the regular business meeting should end by 5:00pm in order to start the TRIM Hearing at 5:01pm, as advertised. He explained that if the regular meeting is not adjourned by 5:00pm, then it will be recessed to allow the TRIM Hearing to start promptly at 5:01pm. The regular meeting would then be reconvened immediately following the TRIM Hearing. He added that to facilitate that process, all action items have been placed on a Consent Agenda.

b) National Kinship Care Awareness Month/Acceptance of Broward County Proclamation

Mr. Wood announced that September is National Kinship Care Awareness Month, a time to recognize the importance of kinship caregiving. He explained that kinship care is when a relative or other family member provides a home for a child who needs support and protection, often when the child's parents are unable to care for them. Kinship care can help children maintain their cultural and familial connections, and promote their well-being. It can also reduce traumatic experiences for children and improve their mental health outcomes.

He also shared that CSC is a sponsor of the Kinship Family Conference 2024, on September 28, 2024, from 9:00am-3:00pm, at the Mt. Hermon A.M.E. Church. The conference will feature workshops, resources, and fun activities for children. Breakfast and lunch will be provided.

Vice Mayor Furr read a proclamation from Broward County in honor of National Kinship Care Awareness Month. Ms. Arenberg Seltzer paid tribute to the late Carole Andrews for her efforts to establish the kinship programs in 2004, noting that her legacy lives on.

IV. President's Report

Good of the Order

Ms. Arenberg Seltzer read a thank you note from a parent in appreciation for JAFCO's CSC-funded summer camp.

Ms. Arenberg Seltzer shared that CSC previously received a proclamation from Mayor Rich and the Broward County Commission in recognition of National Diaper Need Awareness Week. This proclamation was shared with the Miami and Broward Diaper Banks, Healthy Mothers-Healthy Babies, and the Broward Healthy Start Coalition.

Ms. Arenberg Seltzer highlighted the activities surrounding the recent visit of this year's author of the Broward: Read for the Record book, Piper Chen Sings, which included a visit and reading at Walker Elementary School and the Broward County Library Conference on Children's Literature. She added that she participated in a Conference panel discussion on the Broward Reads Campaign and its impact on children and families in Broward.

Ms. Arenberg Seltzer highlighted another great partnership, a celebration of Black Philanthropy Month with the Urban League. CSC staff presented on CSC's Capacity Building efforts and resources. Past recipients of CSC Capacity Building Grants shared their organizational success. Ms. Arenberg Seltzer commended Ms. Kandyss Torrence, CSC's Training Manager, for her efforts in this partnership.

Ms. Arenberg Seltzer shared that Mr. Ken King, CSC's Director of Public Affairs and Organizational Development, and Ms. Kim Reid, CSC's Programs Manager, represented CSC at Feeding South Florida's Broward Hunger Summit. It was a critical initiative during Hunger Action Month to address and strategize solutions for hunger and food insecurity. Mr. King served as a panelist highlighting CSC's work in the hunger mitigation area.

Ms. Arenberg Seltzer highlighted Dr. Remikie's presentation on CSC's leadership, resources, and advocacy at the recent City of Lauderdale Lakes "Conversation with your Commissioners," where the topic was Awareness of Available Support Network for Our Students. She explained it was an evening focused on educating the community on resources for students to assist them throughout the 2024/2025 school year, with a special emphasis on mental health awareness and resources. Other notable presenters included Dr. Hepburn and Florida State Representative Daryl Campbell.

Ms. Arenberg Seltzer highlighted the recent Countering Anti-Semitism Training that was sponsored by the CSC. She noted that it was presented by the American Jewish Committee, with the support of the Broward County

Commission, and was very well done. She explained that the Broward County Commission provides these trainings throughout the County for non-profit employees, parents, and students.

The annual Lights On Afterschool celebration will be held on October 14th at Franklin Park to celebrate the importance of out-of-school time programs for children, youth, and their families. Ms. Arenberg Seltzer explained that unlike previous years, this year's event will feature two sessions, an elementary session and a middle/high school session. The elementary session will take place from 10:30am-12:30pm and the middle/high school session will take place from 1:30pm-3:30pm. Each session will showcase presentations, including drumming, dance, and step, which are typically found in out-of-school time programs.

Ms. Arenberg Seltzer, at the upcoming For the Public Good Gala, will receive The Tony Karrat Excellence in Community Service Award, which was created to honor those who have demonstrated a lifelong commitment to serving the community and making the Broward County area a better and more just place to live for all.

Ms. Arenberg Seltzer noted that the application deadline for the CSC Gubernatorial appointee vacancy has been extended to October 4, 2024.

V. General Consent Agenda

Mr. Wood pointed out that about half of the agenda items had previously been reviewed and recommended by the Program Planning Committee (PPC), and that an Addendum Agenda had been distributed yesterday that includes the renewal of property insurance and workers compensation, as well as approval of the LIP Letter of Agreement (LOA) on behalf of Henderson Behavioral Health.

Ms. Arenberg Seltzer explained that the addendum items had an October 1st deadline and detailed information was just received this week. She highlighted the items, as presented in the addendum mini packet. She noted that the LIP item has no additional cost, as it uses contracts that are already in place with Henderson Behavioral Health. She added that it will be really helpful to them.

- a) August 2024 Council Minutes
- b) September 11, 2024, TRIM Minutes
- c) President/CEO Eval Time Frame and COLA
- d) Investment Quarterly Report

- e) Additional Positive Youth Development (PYD) Youth FORCE Allocations for Hispanic Unity and Crockett Foundation at Two BCPS Sites Beginning October 2024
- f) CareerSource Broward's Summer Youth Employment Contract for FY 24/25
- g) Junior Achievement's Biz Town and Finance Park FY 24/25 Contract Renewal
- h) Children's Home Society of Florida's Family Supervised Visitation Contract Extension Through January 31, 2025
- i) Non-renewal of the Jewish Community Centers of South Broward, Inc., d/b/a David Posnack Jewish Community Center, Contract
- j) Broward Health's Community Collaborative Funding Request to Support the Nurse-Family Partnership Program
- k) Hanley Foundation's Leverage (Match) Request for the DCF Prevention Partnership Grant Award
- l) Reallocation of the Budget for the Center for Hearing & Communication's Family Strengthening Program and Fiscal Sponsor Fees to Unallocated
- m) Receipt of the Promise Neighborhood Grant Funding & Related Expenditures and Contract(s) with Florida Atlantic University (FAU)
- n) Junior Achievement's Summer Youth Employment Leverage Contract
- o) Contract Adjustment to the Tri-Party Agreement with the Center for Hearing & Communication and KID to Include Fiscal Sponsor Fees for FY 23/24
- p) Reallocation of the Budget for Our Children, Our Future, Inc., PYD 2024 RFP Youth FORCE Program to Unallocated
- q) M Network as the Communication and Public Affairs Consultant for FY 24/25
- r) FY 24/25 Public Awareness Media Plan
- s) Funds and Related Expenditures from the Jim Moran Foundation for Broward: Read for the Record FY 23/24
- t) Write-off of Title IV-E Receivables FY 21/22

- u) Budget Amendments & Interim Financial Statements for August 2024
- v) Investment Statements for August 2024
- w) Monthly/Annual Purchases for September 2024 and FY 24/25
- x) Insurance Renewals for Property Insurance and Worker's Comp
- y) Letter of Agreement (LOA) with the Agency for Health Care Administration (AHCA) on Behalf of Henderson Behavioral Health

ACTION: Vice Mayor Furr made a motion to approve the Consent Agenda and the Addendum Agenda, which included approval of the August 15, 2024, Council meeting minutes; approval of the September 11, 2024, TRIM Hearing minutes; adjustment of the President/CEO evaluation time frame from October/November to January/February; approval of a Cost-of-Living Adjustment (COLA) for the President/CEO effective October 1, 2024; acceptance of the Investment Quarterly Report for the Quarter ended June 30, 2024; approval of additional PYD Youth FORCE allocations for Hispanic Unity and Crockett Foundation at two BCPS sites beginning in October 2024; approval of the renewal of the CareerSource Broward deferred Summer Youth Employment Contract for FY 24/25; approval of Junior Achievement's Biz Town and Finance Park FY 24/25 Contract renewal; approval of Children's Home Society of Florida's Supervised Visitation Contract extension through January 31, 2025; non-renewal of the Jewish Community Centers of South Broward, Inc., d/b/a David Posnack Jewish Community Center, Contract; approval to update Service Goal 9, Objective 091 in Goals with Words and remove words "using the Healthy Families America model;" approval of Broward Health's Community Collaborative funding request to support the Nurse-Family Partnership Program; approval of additional funding for the Hanley Foundation's leverage (match) request for the DCF Prevention Partnership Grant (PPG) award; approval of the reallocation of the budget for the Center for Hearing and Communication's Family Strengthening Program and Fiscal Sponsor fees to Unallocated; approval of the receipt of 2024 and 2025 Broward Promise Neighborhood (PN) Grant funding and related expenditures; approval of contract(s) with Florida Atlantic University (FAU) pending final legal approval; approval of the leverage funding renewal for Junior Achievement to provide summer youth employment opportunities to economically-disadvantaged youth for FY 24/25, contingent on leverage confirmation; approval of the contract adjustment to the tri-party agreement with the Center for

Hearing & Communication and KID to include Fiscal Sponsor fees for FY 23/24; approval of the reallocation of the budget for Our Children, Our Future, Inc., Positive Youth Development 2024 RFP Youth FORCE Program to Unallocated; approval of M Network as the Communication and Public Affairs Consultant FY 24/25; approval of the Public Awareness Media Plan FY 24/25; acceptance of funds and related expenditures from the Jim Moran Foundation for Broward: Read for the Record for FY 23/24; approval of the write-off of Title IV-E receivables for FY 21/22; approval of Budget Amendments and Interim Financial Statements for the period ending August 31, 2024; acceptance of monthly statements for the Managed Fund from PFM and US Bank for August 31, 2024; approval of the CSC monthly/annual purchases for September 2024 and FY 2024/2025; approval of insurance renewals for Philadelphia Indemnity Insurance Company and MEMIC Indemnity Company for property insurance and worker's compensation, respectively, for FY 24/25; approval of the Letter of Agreement with the Agency for Health Care Administration (AHCA) on behalf of Henderson Behavioral Health, all as presented. The motion was seconded by Dr. Thaqi and passed with no opposing votes.

- VI. Public Comment
- VII. Council Members' Comments
- VIII. Adjournment

The meeting adjourned at 4:24 pm with a motion from Vice Mayor Furr and a second from Dr. Thaqi.

Dr. Christine Thompson, Secretary

ATTACHMENT 1

MEETING ATTENDEES (*denotes speaker)

Name	Organization
Grace Ramos	The M Network
Thom Mozloom	The M Network
Elizabeth Dorante	Hispanic Unity of Florida
Alison Bregman-Rodriguez	YMCA of South Florida
Jarvis Brunson	Change Me Foundation Inc.
Traci Schweitzer	Department of Children and Families
Cyndi Barry	Harmony Development Center
Kimberly Adams	N/A
Alice-Lydia Bird	YMCA of South Florida
Donna Lavalle	Smith Community Mental Health

TAB 24

For Council Meeting October 17, 2024

- Issue:** Set Monthly Meeting Dates for 2025.
- Action:** Approve the Proposed Monthly Meeting Dates for 2025.
- Budget Impact:** None.
-
-

Background: Every October, the Council approves the meeting dates for the next calendar year. Since 2001, the monthly meeting has been held from 9:30 am to Noon on the third Thursday of the month, except for September. The September meeting is traditionally held in the afternoon one hour prior to the second of two required Truth in Millage (TRIM) hearings, which must take place after 5:01 pm on a date that does not conflict with the TRIM Hearings of the Broward County Commission or the School Board of Broward County. In order to accommodate the statutory requirement, the September CSC meeting often falls on a day other than the third Thursday of the month. Also, the May meeting is generally a day-long Budget Workshop that goes into the mid-afternoon, and the July and December meetings have traditionally been canceled to accommodate extended summer and holiday vacations.

Current Status: Attached is the proposed schedule for 2025. The calendar maintains the CSC monthly meetings on the third Thursday of the month, from 9:30 a.m. to Noon, at the CSC Office (6600 W. Commercial Blvd., Lauderhill, FL 33319), with the exceptions of the September Council meeting, the two TRIM Hearings in September, the estimated end time of the May Budget Retreat, and the June Council meeting that happens to fall this year on the Juneteenth Federal Holiday. A calendar poll was sent to Members in advance to determine a June meeting date and it appears that June 18 is the winner.

Please note that the proposed September dates are marked “tentative” until we are notified in early Spring of any conflicts with the County or School Board’s TRIM Hearings. If that happens, staff will bring back alternative September dates for Council approval. We will also try to coordinate with CSC Palm Beach to avoid the same Hearing dates, since we now share a Member. The July and December monthly meetings are also marked “tentative” until they are cancelled by a Council vote the month or two before.

Recommended Action: Approve the Proposed Monthly Meeting Dates for 2025

CHILDREN'S SERVICES COUNCIL OF BROWARD COUNTY
2025 Council Meeting Calendar

Council Meeting, Thursday, January 16, 2025, 9:30am

Council Meeting, Thursday, February 20, 2025, 9:30am

Council Meeting, Thursday, March 20, 2025, 9:30am

Council Meeting, Thursday, April 17, 2025, 9:30am

Council Meeting/Budget Workshop, Thursday, May 15, 2025, 9:30am-4:00pm

Council Meeting, Wednesday, June 18, 2025, 9:30am

(Tentative) Council Meeting, Thursday, July 17, 2025, 9:30am *(Tentative)*

Council Meeting, Thursday, August 21, 2025, 9:30am

(Tentative) T.R.I.M. Public Hearing, Thursday, September 4, 2025, 5:01pm *(Tentative)*

(Tentative) Council Meeting, Thursday, September 18, 2025, 4:00pm *(Tentative)*

(Tentative) T.R.I.M. Public Hearing, Thursday, September 18, 2025, 5:01pm *(Tentative)*

Council Meeting, Thursday, October 16, 2025, 9:30am

Council Meeting, Thursday, November 20, 2025, 9:30am

(Tentative) Council Meeting, Thursday, December 18, 2025, 9:30am *(Tentative)*

Please Note:

September meetings are subject to change due to any public hearing date conflict with the Broward County Commission or School Board of Broward County schedules. If the above September dates change, an updated calendar will be distributed to Members and posted on the CSC website (www.cscbroward.org). All other meetings are also subject to change and the CSC website should be consulted.

All meetings will be held at the CSC Office, 6600 West Commercial Boulevard, Lauderdale, FL 33319, along with a virtual viewing option.

Council meeting packet information will be posted on the website, www.cscbroward.org, by the Monday before each meeting. Only the agenda will be available at the meeting.

Please complete this form <https://bit.ly/3nbSwe9> for ASL interpreter requests. For all other requests for special accommodations, please reach out to Betty Dominguez at (954) 377-1665 or bdominguez@cscbroward.org at least one week in advance so that proper arrangements can be made.

If you have questions or need additional information, please contact Amy Jacques at (954) 377-1675.

TAB 25

For Council Meeting October 17, 2024

Service Goal 1 Support provider agency efforts to enhance their infrastructure and service delivery effectiveness.

Objective: 013 Promote collaboration between funders & stakeholders to improve the delivery of children's services across local systems.

Issue: Update A Little Help Never Hurts Agreement to include Fiscal Sponsor Urban League of Broward County and the related Fiscal Sponsor fees.

Action: Approve Urban League of Broward County as the Fiscal Sponsor for A Little Help Never Hurts, Triparty agreements.

Budget Impact: \$14,500 Of \$30,725 Available in Goal 013 for FY 24/25.

Background: The Financial Viability test is administered during the RFP application process, whenever leverage or other non-RFP requests are made, and prior to each renewal period thereafter. The test reviews various fiscal elements that may restrict the maximum amount awarded to an agency within a single CSC fiscal year or require a fiscal sponsor to get unlimited funding. All CSC-funded agencies are required to submit audited financial statements within 180 days of their fiscal year-end. A Little Help Never Hurts (ALHNN) requested an extension for submitting their audit until October 31 due to some restructuring they are doing to handle the large increase in grant funding from CSC.

Current Status: Urban League of Broward County, an existing CSC-funded provider who passed the financial viability test with no award limitations, has agreed to be the Fiscal Sponsor for ALHNN. This solution will allow the agency to receive additional technical support for their growth. The contracts and related fiscal fees are listed below:

Program	Fiscal Sponsor Fee FY24-25
A Little Help Never Hurts - Contract # 23-6720 October 1, 2024 - September 30, 2025	\$12,958
Promise Neighborhood October 1, 2024-December 31, 2024	\$1,542
Total	\$14,500

Recommended Action: Approve Urban League of Broward County as the Fiscal Sponsor for A Little Help Never Hurts, Triparty agreements.

TAB 26

For Council Meeting October 17, 2024

System Goal	SYS 1.2 Research and Evaluate Systems of Care.
Objective:	SYS 923 Collaborate with community partnerships to promote child and family research initiatives.
Issue:	Community Participatory Action Research Arts Exhibition.
Action:	For Your Information Only.
Budget Impact:	Not Applicable.

Background: With funding from the University of Pennsylvania's Actionable Intelligence for Social Policy (AISP), CSC and partners completed a Community Participatory Action Research (CPAR) project with co-researchers consisting of parents and older youth with lived experience with the Baker Act system in Broward and professionals from the behavioral health care system in 2023. In February 2024, the Council approved \$5,000 of the remaining UPENN funds to secure a local cultural artist, Niki Lopez, founder of What's Your Elephant, LLC, to: 1) create the theme and marketing & social media materials based on the CPAR work; 2) secure local artists; 3) work with the artists and the co-researchers to plan the art exhibition; and 4) materials and labor for installing the artwork. In June 2024, the Council approved funding the procured organization, What's Your Elephant, to provide Cultural Arts Exhibition Hosting Services which included pass through funds for payment of the artists, the venue and the caterer.

Current Status: The month-long Echoes of Empathy interactive arts exhibition successfully engaged hundreds of community members and system partners at the Hollywood Arts Park Gallery and online. What's Your Elephant, LLC, implemented (1) a gallery with works from three local artists, other artists' work who responded to an open call, and art from youth who have lived experience being Baker Acted in Broward; (2) opening night performances, (3) a gallery walk/wellness activity/reflection with system leaders, (4) a hybrid community conversation with youth/families who have lived experience being Baker Acted, system professionals, and the artists and (5) a closing art-making event at the gallery. Approximately, 200 people attended the opening, 20 people attended the Elected Officials/System Leaders activity, 50 people participated in the hybrid community conversation, and about 30 people attended the closing. There were over 5,000 views of Facebook Reels and 22,000 impressions (some of which may have been bots) and significant social media activity that spiked during the month-long event.

Youth, parents, and families who participated in the exhibit shared how the experience reduced the stigma associated with mental illness, helped them feel less alone and isolated, and educated them on opportunities for improving the experience and outcomes of individuals experiencing mental health crises. The partnership with What's Your Elephant demonstrated the value of the arts in communicating research to a wider audience, providing healing spaces/experiences for youth, families and communities, and enhancing opportunities for policy and system change.

Recommended Action: For Your Information Only.

TAB 27

For Council Meeting October 17, 2024

System Goal:	SYS 1.2 Research and Evaluate Systems of Care.
Objective:	SYS 923 Collaborate with community partnerships to promote child and family research initiatives.
Issue:	Broward Consent Management Initiative.
Action:	For Your Information Only.
Budget Impact:	Not Applicable.

Background: As shared in the March 2024 Good of the Order, Sue Gallagher, CSC's Chief Innovation Officer (CIO), and Julie Klahr, Broward Behavioral Health Coalition (BBCH) legal counsel, were invited to present and participate in the Steward's of Change national "Consent Learning Lab" at the Health Information Management Systems Society (HIMSS) conference in Orlando. The invitation was extended based on the Broward Data Collaborative's work with Amazon Web Services and Velatura Public Benefit Corporation on the We Are Supported Integrated Data System (IDS) and the Community Participatory Action research project with youth and their families who experienced the Baker Act in Broward.

CSC's CIO served on the "The Art of the Actual: Consent-to-Share Vision, Approaches and Models for Managing Multisystem Involved Clients" panel and shared the consent form and process created with the attorneys involved in the We Are Supported IDS work: Garry Johnson (CSC), Julie Klahr (BBCH), and Shauna Thomas (ChildNet). The Consent Learning Lab participants included representatives from federal organizations like Health and Human Services and the Office of National Coordinator for Health Information Technology, Harvard Medical School, States (ie., California), Insurance companies (ie., Blue Cross), and the San Diego Community Information Exchange.

Current Status: The CSC and Broward Data Collaborative Partners work to develop a family friendly consent form to notify care team members when a young person is Baker Acted informed the report "Catalyzing Whole Person Care: Consent to Share is Key: Insights, Next Steps, and Road Map." Here is a link to the report: https://stewardsofchange.org/wp-content/uploads/sites/2/2024/09/SOCI_report.pdf. Specifically, Broward's experience informed key findings which included strong partnerships and collaboration, customizing the process from the user (ie., youth, parent, family, adult) perspective, and addressing regulatory requirements in the social

services field (see pages 34, 35, and 37 for CSC contributions). The report also provides a list of domains necessary for universal consent (ie., social services, health, justice, research, etc.); a proposed taxonomy of consent standards including the types, purposes, regulations, scope, levels of consent, etc; and considerations/questions to guide the development of consent forms.

Recommended Action: For Your Information Only.

TAB 28

For Council Meeting October 17, 2024

Service Goal **7** Improve the availability and quality of out-of-school time programs to promote school success of children living in economically disadvantaged neighborhoods.

Objective: **072** Provide quality out-of-school programs to support school success for children living in economically disadvantaged neighborhoods.

Issue: Back to School Extravaganza 2024 Activity Report and Budget to Actual Expenditures

Action: Approve Acceptance of Revenue and Reconciliation of Expenditures for the Back-to-School Extravaganza FY 23/24

Budget Impact: \$7,150.65 Revenue of Community Donations directly to CSC Allocated to Goal 072 for FY23/24.

Background: This is the 14th year that the Council provided a challenge grant to fund Back to School supplies for 10,000 Broward County students.

Current Status: The Back-to-School Extravaganza (BTSE) remains a key initiative in supporting students across Broward County. This year's BTSE events were successful in distributing essential school supplies and community resources to thousands of families. The contributions of various partner organizations were critical in ensuring the success of these events.

Organization	Dollars
Neighbors 4 Neighbors	\$2,050.65
Florida Blue	\$2,600.00
SFLEd Fed Credit Union	\$2,500.00
Total	\$7,150.65

This year, BTSE distributions were hosted at the following locations: Dillard 6-12 School, Miramar High School, and Blanche Ely High School. During these events, over 8,000 participants received backpacks, school supplies, shoes, underwear and access to a variety of community resources. These distributions provided students and families with the essential tools and services they need for the upcoming school year.

In 2024, staff introduced new “Boutique” BTSE events to meet the needs of specific student populations. Deerfield Beach High School Freshman Orientation Boutique event was designed to support incoming freshmen by providing school supplies and connecting them with resources tailored to youth. The Broward County Public Schools (BCPS) New Family Welcome Meeting at Indian Ridge Middle School was held on September 11, 2024, and provided a specialized resource fair for families new to the country.

The 2024 BTSE and the introduction of boutique events have made a significant impact on students and families in Broward County. With the support of partner organizations, this initiative continues to enhance access to essential resources, ensuring students are equipped for success in the new school year. The following outlines the detailed revenue and expenses associated with the event, providing a clear breakdown of income sources and costs incurred:

Budget:	Dollars
Original CSC Budget	\$262,500.00
Additional Council Approved Budget	\$155,840.00
Community Donations	\$7,150.65
DeLuca Foundation	\$33,092.00
Total Budget for Back-To-School Extravaganza	\$458,582.65

Expenditures:	Quantity	Dollars
Backpacks	10,000	\$170,875.00
Uniforms	10,008	\$185,122.80
Shoes	2,916	\$24,824.00
Undergarments	18,360	\$33,172.79
Boutique Bags	1,000	\$2,250.00
Laundry Sheets	42 cases	\$3,022.00
Total Expenditures		\$419,266.59

Net Remaining Budget (goes into Fund Balance) \$39,316.06

In-Kind Donations (FYI) \$128,027.57

Note: Community Foundation Available Balance \$14,710.12
May be used next year

Recommended Action: Approve Acceptance of Revenue and Reconciliation of Expenditures for the Back-to-School Extravaganza FY 23/24

TAB 29

For Council Meeting October 17, 2024

Service Goal	5 Improve the educational success of young children.
Objective:	053 Provide leadership and support for the Community-wide Grade Level Reading Campaign, including literacy and early education support (PreK through 3rd grade) and other resources for children, parents, and teachers.
Issue:	Collaborate with Community Partners to Increase Literacy Skills by Supporting Family Literacy.
Action:	Approve Funding to Purchase Local Author Books for Family Literacy event.
Budget Impact:	\$3,750 Of \$100,000 Available in Broward Reads – Campaign for Grade-Level Reading Goal 053 for FY 24/25.

Background: Research consistently highlights the critical importance of reading proficiency by the end of 3rd grade as a predictor of long-term academic and life success. Data reveals that 74% of students who do not achieve reading proficiency by this milestone face academic challenges in later grades, with many ultimately dropping out before earning a high school diploma. Achieving proficiency allows students to transition from “Learning to Read” to “Reading to Learn,” equipping them with the skills needed to master increasingly complex subjects in higher grades.

The Broward Reads: Campaign for Grade Level Reading represents a comprehensive initiative aimed at improving literacy outcomes in Broward County. This campaign engages families and communities, providing necessary resources while fostering a culture of reading. By focusing on family involvement and literacy education, the initiative not only improves academic outcomes for children but also strengthens family bonds and contributes to overall community well-being.

Current Status: Family literacy is an essential component of educational development and community well-being and helps establish a strong foundation for children's educational success. November is Family Literacy Month. The CSC and the Broward Reads have been asked to partner with Broward County Public Schools (BCPS) in a District-wide read-aloud with the Superintendent of Schools. The book to be highlighted is “*No Grades, No Play*” by Ray Shipman, a local children’s author. It is about Jason, who dreams of making it all the way to the BIG LEAGUES as a professional football player and joins him on his adventure as he learns valuable lessons on how to balance school and sports and the importance of education. 250 copies of the book @ \$15 each, will be purchased from The Minnis Group for a total of \$3,750. The books will be signed by the author and distributed to families when they attend the Family Literacy event on November 10.

Recommended Action: Approve Funding to Purchase Local Author Books for Family Literacy event.

For Council Meeting October 17, 2024

- Issue:** Budget Carry Forward for selected POs and Initiatives.
- Action:** Approve Budget Carry-Forward for selected POs and Initiatives.
- Budget Impact:** \$203,394 Additional Budget in Various Lines for FY 24/25.
-
-

Background: Each year there are Purchase Orders (“PO”) and contracts where the work may not have been completed during the fiscal year or the contract spans fiscal years. These POs and related budget amounts are “carried forward” into the new fiscal year and presented at the November Council meeting once the transactions from the prior year have all been submitted. However, there are several projects spanning the FY where it is imperative that the work continues without interruption. For these select Purchase Orders and initiatives, the budgeted amounts to carry forward into FY24/25 are known, and it is likely payments will need to be made in October.

Current Status: Attached is a schedule detailing the requested carry forward items that need to be carried forward in October for FY 2024/25. These items include programmatic contracts, technology projects, property insurance, facilitated related items that span fiscal years, and other miscellaneous POs that the items are expected in the next month or so. The list of remaining budget carry-forward items will be presented to the Council in November once all the data is recorded and analyzed.

Recommended Action: Approve Budget Carry-Forward for selected POs and Initiatives.

Children's Services Council of Broward
Budget Carry Forward from FY 23/24 to FY 24/25
General

				OCT 24 for FY 25
Goal	GOAL NAME	PROVIDER	DESCRIPTION	Requested CF Amount
<u>Service Goals:</u>				
031	Youth Force	Wyman TOP training	Additional Staff Training	\$8,500
035	Youth Program Initiatives	U Turn consulting	Teen chat consulting	\$11,000
		Publix & Various Vendors	U-Turn Teen-chat logistics and refreshments	\$4,839
053	Grade Level Reading	Jumpstart for Young Children	200 books FY 24- Broward Reads -Piper Chen Sing:	\$950
924	Integrated Data System	Community Cares Partnership	funds rec'd JAN 2024 Never used	\$50,000
Total Goals				<u>\$75,289</u>
<u>Administration: Purchase Orders that Span FY</u>				
		United Data Technologies	Cloud Migration of Active Directory	\$25,680
		Marsh & McLellan	Property Insurance	\$21,000
				<u>\$46,680</u>
<u>Facilities Related:</u>				
		Best Roofing	Facilities Reserves	\$8,000
		Cornerstone Property Care	Facilities Reserves	\$12,400
		Orangement Development and Const	Facilities Reserves	\$60,025
		Project Contingency Fund	Facilities Reserves	\$1,000
				<u>\$81,425</u>
Total Administration, Capital Outlay & Facility Related				<u>\$128,105</u>
Total Carry Forwards				<u>\$203,394</u>

For Council Meeting October 17, 2024

Issue: Disposal of Fully Depreciated Fixed Assets and Non-Capitalized Items

Action: Approve Disposal of Fully Depreciated Fixed Assets and Non-Capitalized Items for FY23-24

Budget Impact: N/A

Background: The Council is responsible for approving all purchases and the disposal of fixed assets and non-capitalized electronic equipment from the premises. In October 2020, the Council approved increasing the threshold for fixed assets from \$1,000 to \$5,000 to comply with the rules of the Florida Department of Financial Services. The CSC's policy/procedures for the retention period remain unchanged. According to the policy, computer hardware/software is depreciated over a three-year period, furniture and fixtures over a five-year period, and electronic equipment that does not meet the \$5,000 threshold is not capitalized and, therefore, not depreciated, but it is still tracked for accountability purposes.

Current Status: Attached for your approval is a list of items to be disposed of for the fiscal year, which ended on September 30, 2024. The list for both capitalized and non-capitalized items primarily includes old computers and other equipment that are outdated and no longer in use as technology continues to evolve. The net book value for all items is zero pursuant to the depreciation schedule explained above and does not result in an expense in the financial statements. Rather, the disposal of fixed assets is only reflected in the government-wide statements in the Annual Comprehensive Financial Report.

If applicable, certain electronic parts may be cannibalized to be used in other machines. The salvageable computers/parts will be donated to Green Owl Tech Recycling or a similar organization. Once the computers are refurbished, they are donated to CSC providers or other agencies in the Tri-County area to help bridge the Digital Divide.

Recommended Action: Approve Disposal of Fully Depreciated and Non-Capitalized Items for FY23-24

**Children's Services Council of Broward County
FY 2024 Asset Disposal List
for Council Meeting Date - October 17, 2024**

<u>Description</u>	<u>Acquisition Date</u>	<u>Acquisition Cost</u>	<u>Accumulated Depreciation</u>	<u>Net Book Value</u>
Cisco 4431 ISR Router	7/10/2020	\$13,715.57	\$13,715.57	\$0.00
Z-Boost Cell Repeaters	2/26/2010	\$13,012.00	\$13,012.00	\$0.00
Security Cameras Server	9/22/2015	\$7,665.84	\$7,665.84	\$0.00
Six Security Cameras	8/20/2017	\$7,230.50	\$7,230.50	\$0.00
File System	9/29/2009	\$6,035.20	\$6,035.20	\$0.00
Z-Boost Cell Repeaters	9/30/2010	\$5,323.50	\$5,323.50	\$0.00
Upgrade Cisco Communication Ro	9/29/2020	\$3,300.00	\$3,300.00	\$0.00
UPS Above Ceiling/Door	3/21/2010	\$1,992.42	\$1,992.42	\$0.00
Dell Precision 7730	11/26/2018	\$1,925.00	\$1,925.00	\$0.00
CISCO CAT 2960-X48GE POE	6/18/2017	\$1,668.00	\$1,668.00	\$0.00
Dell 5510-15-10210U 500/8 W10P	8/27/2020	\$1,125.00	\$1,125.00	\$0.00
Dell 5510-15-10210U 500/8 W10P	8/27/2020	\$1,125.00	\$1,125.00	\$0.00
Dell 5510-15-10210U 500/8 W10P	8/27/2020	\$1,125.00	\$1,125.00	\$0.00
Total Capital Assets		\$65,243.03	\$65,243.03	\$ -
Total Non-Capital Assets		\$7,782.90		
Total Capital & Non-Capital Assets to be Disposed		\$73,025.93		

TAB E

For Council Meeting October 17, 2024

Issue: Monthly Statements for the Managed Fund.

Action: Accept Monthly Statement for the Managed Fund from US Bank for September 30, 2024.

Budget Impact: N/A.

Background: At the November 18, 2021, Council Meeting, the Council approved establishing a Managed Investment Fund consisting of longer-term securities for the core investments. PFM Asset Management LLC manages this fund in accordance with CSC's Investment Policy, with US Bank providing custodial cash services. This longer-term portfolio maintains safety while adding additional yield to the overall investments. Together, PFM and US Bank manage the funds which will be measured against several highly respected industry performance indexes to ensure the portfolio remains on track.

In accordance with the Investment policy, the Council approved at the June 2022 meeting, that staff would bring forth a summary of the monthly statements from both PFM and US Bank to the Council; however, if any Council Member has questions or wants additional information, the entire statement is available for review. PFM will present a fund performance report to the Finance Committee at the end of each quarter which any Council Member is welcome to attend.

Current Status: As of September 30, 2024, the balance of the Managed Fund is \$27,082,512 and includes a net gain of \$220,133 over the prior month. Due to the inclement weather in Orlando, the PFM statement for September 30, 2024, was not received in time for this Council packet. Therefore, you are only being asked to accept the monthly statement from US Bank.

Recommended Action: Accept Monthly Statement for the Managed Fund from US Bank for September 30, 2024.

00021001
57-!-01-B -62 -278-01
0101 -11-03800-01



CSC BROWARD COUNTY - CORE PORTFOLIO!
ACCOUNT UUUUU000

Page 3 of 54
Period from September 1, 2024 to September 30, 2024

MARKET AND COST RECONCILIATION

	09/30/2024 MARKET	09/30/2024 FEDERAL TAX COST
Beginning Market And Cost	26,862,379.06	26,636,213.05
Investment Activity		
Interest	56,237.71	56,237.71
Realized Gain/Loss	6,174.58	6,174.58
Change In Unrealized Gain/Loss	123,417.27	.00
Net Accrued Income (Current-Prior)	34,711.64	34,711.64
Total Investment Activity	220,541.20	97,123.93
Plan Expenses		
Trust Fees	- 408.02	- 408.02
Total Plan Expenses	- 408.02	- 408.02
Net Change In Market And Cost	220,133.18	96,715.91
Ending Market And Cost	27,082,512.24	26,732,928.96

00021001
57-!-01-B -62 -278-01
0101 -11-03800-01



CSC BROWARD COUNTY - CORE PORTFOLIO!
ACCOUNT UUUUU000

Page 4 of 54
Period from September 1, 2024 to September 30, 2024

CASH RECONCILIATION

Beginning Cash	.00
Investment Activity	
Interest	56,237.71
Cash Equivalent Purchases	- 333,790.41
Purchases	- 1,451,404.05
Cash Equivalent Sales	296,702.38
Sales/Maturities	1,432,662.39
Total Investment Activity	408.02
Plan Expenses	
Trust Fees	- 408.02
Total Plan Expenses	- 408.02
Net Change In Cash	.00
Ending Cash	.00

ASSET SUMMARY

ASSETS	09/30/2024 MARKET	09/30/2024 FEDERAL TAX COST	% OF MARKET
Cash And Equivalents	108,849.86	108,849.86	0.40
U.S. Government Issues	17,380,890.52	17,166,628.18	64.18
Corporate Issues	6,876,406.62	6,782,618.23	25.39
Foreign Issues	2,228,306.25	2,185,619.10	8.23
Municipal Issues	233,845.40	235,000.00	0.86
Total Assets	26,828,298.65	26,478,715.37	99.06
Accrued Income	254,213.59	254,213.59	0.94
Grand Total	27,082,512.24	26,732,928.96	100.00

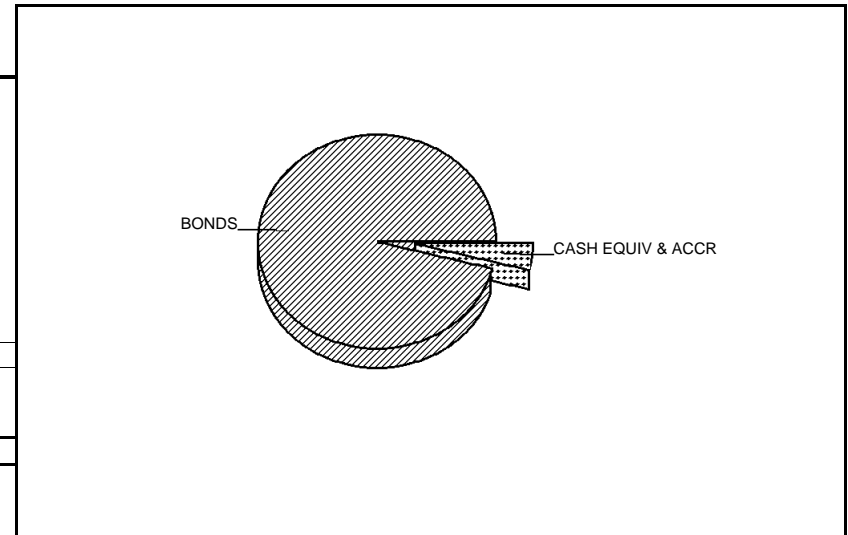

Estimated Annual Income **1,103,269.53**

ASSET SUMMARY MESSAGES

Estimated Annual Income is an estimate provided for informational purposes only and should not be relied on for making investment, trading, or tax decisions. The estimates may not represent the actual value earned by your investments and they provide no guarantee of what your investments may earn in the future.

TAB F

For Council Meeting October 17, 2024

Issue: CSC Monthly Purchases for Administrative Operations.

Action: Approve CSC Monthly Purchases.

Budget Impact: See attached Report.

Background: The State Statute creating and governing the CSC, Chapter 2000-461, as amended, states:

Section 6: No funds of the council shall be expended except by check as aforesaid, except the expenditure of petty cash or the issuance of checks made payable for sums no greater than \$5,000, shall be expended without prior approval of the council, in addition to the budgeting thereof.

The Council's procurement policies and procedures stipulate that expenditures are approved by the Council prior to being expended. As such, the financial system requires a Council Approval (CA) date at multiple points throughout the system including all processed payments. Internal controls for tracking expenditures in accordance with the statute are validated by auditors every year and there have been no significant deviations since the inception of the Council.

Since 2004, at the Council's direction, staff has been instructed to only provide backup material for purchases over \$10,000. As always, backup for purchases below \$10,000 is available upon request.

Current Status: In accordance with policy, please find attached the Invoices, Travel, Purchase Orders, etc., for the month of October 2024 and a few purchases made in late September that are under the CEO's approval authority but have yet to be Council approved. The staff has segregated the items into various categories to facilitate reviewing the various purchases. All purchases listed are within the budget approved by the Council at TRIM as amended from time to time.

Please note that items over \$10,000 have a specific Issue Paper or copy of the related back-up attached to further explain the expenditure. Additional information for **any** expenditure is available upon request.

Recommended Action: Approve CSC Monthly Purchases.

Budget Impact: See attached Report.



**List of Invoices, Travel, Purchase Orders, Sponsorships, etc.
Submitted to the Children's Services Council
October 17, 2024**

Vendor	Description	Amount	Comment (Back-up documentation is available upon request.)
Purchase Orders (less than \$10,000):			
All Couty Maintenance	Ballast Installation	\$ 1,967	FY 24 Purchase
All Service Locksmith	Lock Installation 1st Floor Marketing Closet	\$ 382	FY 24 Purchase
Brunot Maps	Consulting to create GIS Map of Place Based Hubs.	\$ 5,000	
Yoshino Architectuve	Front Door Installation	\$ 3,500	FY 24 Purchases
Employee Travel and Training:			
Jennifer Wennberg	National Independent Living Conference; 10/1/24 - 10/3/24; Orlando	\$ 180	
Kenneth King; Sharetta Remikie	OIC of South Florida Middle Class Summit;10/2/24; Fort Lauderdale	\$ 250	
Sue Gallagher	Love is Local Summit; 10/10/24; Orlando	\$ 305	
Kandyss Torrence	Virtual Training Series; 10/11/24 - 12/13/24;	\$ 725	
Michelle Hagues-Fullwood	Celebrate Babies; 10/22/24; Virtual	\$ 25	
The People Institute	PS Department Team Building, All Staff Coaching & Training and Succession Support.	\$ 9,627	
Trainers / Material (Service Goal 011) Provider names and courses may be subject to change: Instructor Led Unless Otherwise Indicated:			
Collectively - A Radlauer Venture	Creating Community at Work: Prioritizing Wellness and Belonging	\$ 3,500	Inclusivity
Group Victory	Marketing for Nonprofits	\$ 348	Organizational Development; Additional Amount Requested
ReadySetMore	Mastering Difficult Conversations	\$ 788	Organizational Development
ReadySetMore	Speak in Public Like a Pro	\$ 2,364	Organizational Development
The People Institute	Board Bylaws	\$ 788	Organizational Development
The People Institute	Robert's Rules	\$ 788	Organizational Development

TAB G

Funders Forum Meeting Summary

October 4, 2024

Members Present:

Amy Moore, Early Learning Coalition (ELC); **Angelica Rosas**, Community Foundation; **Carol Hylton**, CareerSource; **Cassandra Burell**, Community Foundation; **Cassandra Evans**, Broward County Human Services Department; **Dion Smith**, Children's Services Council (CSC); **Efrem Crenshaw**, Broward County Human Services Department; **Elida Segrera**, Broward Behavioral Health Coalition (BBHC); **Fiorella Smyth**, Florida Blue; **Judith Fletcher**, Frederick A. DeLuca Foundation; **Keyonia Lawson**, CSC; **Kristen Stevens**, Carl Angus DeSantis Foundation; **Lisa Bayne**, CSC; **Lori Canning**, Broward County Public Schools; **Maria Hernandez**, United Way; **Maria Juarez Stouffer**, CSC; **Monica King**, Broward Healthy Start Coalition (BHSC); **Norma Wagner**, Department of Children and Families (DCF); **Radoika (Rady) Pilarte**, CSC; **Renee Podolsky**, Florida Department of Health; **Shantay Sharpe** for Teves Bush, Department of Juvenile Justice (DJJ); **Sheri Brown Grosvenor**, Community Foundation; **Traci Schweitzer**, DCF

Welcome and Introductions:

Maria J. S. welcomed members and introductions were completed.

Approval of the August 2, 2024, Meeting Minutes:

Cassandra E. moved to approve the minutes as presented. Lori C. seconded the motion, which passed with no opposing votes.

Discussion regarding Navigation Services

Maria J. S., Dion S., and Lisa B. spoke to members about CSC's funded program, Healing and Empowering All Living with Trauma (HEAL). HEAL addresses community trauma and its negative impacts by providing resources to strengthen resiliency for impacted children/youth and their families.

The HEAL Trauma program utilizes Community Mental Health Workers (CMHW) who are from the community to be served. The CMHWs provide navigation services by linking youth and their families to available community services and helping them navigate the systems of care. The CMHWs serve the Northeast, Central East, and Southeast regions of Broward County. This program is due to sunset on 9/30/2024, and a new procurement will be released in January 2025.

CSC will also be a sub-awardee of the Promise Neighborhood Grant, which is led by FAU and includes a navigation and linkage component provided by Urban League.

CSC has also rolled out a partnership with BBHC and 2-1-1 First Call For Help's Behavioral Health Hotline to provide navigation services for families with children who have behavioral health concerns and don't know where to go for help or how to navigate the behavioral health system to obtain services. The 2-1-1 Behavioral Health Hotline will track the referral, whether the linkage was successful, and any system barriers. If an additional level of assessment is needed, then the client will be referred to BBHC.

Maria J. S. asked members to share details about the programs they fund or oversee that provide navigation and linkage to services.

Maria H. shared that United Way currently funds 3 navigation programs similar to HEAL Trauma and is ready to release another procurement to fund these programs. Their current program focuses on services to the Latino population in the 33321 area and will serve the family as a whole.

Sheri B. G. asked how the CMHW connects to the community. Lisa B. explained that they participate in a variety of community-based events, such as block parties and parades. They also support families when there is a community tragedy, as they are trusted members of the community, have developed relationships, and are able to find out what the community needs and navigate to needed services.

Lori C. shared that BCPS schools have a student support initiatives team led by Jodi Washington. Jodi Washington leads their counselors and mental health support and navigation services and works closely with United Way and CSC's afterschool program providers.

Cassandra E. shared that the County's Human Services Department's navigation services have ties to several of their grants such as permanent supportive housing and rapid rehousing, emergency shelters, street outreach program, and housing navigation that is tied to their Ryan White program, and their advocacy program that is for children with special needs to help them navigate through various systems, but there is no stand-alone navigation program.

Cassandra E. raised the question about continuing training for the CMHW to understand the system of care. Maria J. S. explained that CSC is currently contracted with BBHC to provide 30 hours of training and 500 hours of supervision that provide the foundation for the CMHW to be eligible to take the state community healthcare worker certification exam. CSC also requires and offers free for the CMHWs a full cadre of additional required training. In the new HEAL Trauma RFP, CSC is reimagining the training component and will issue a separate procurement for this component.

Monica K. shared about BHSC and BBHC's peer-to-peer navigation support services for behavioral health, housing, and employment needs. BHSC's focus is on pregnant women and new moms who need assistance. Monica K. also mentioned that the new Medical

Health Plans will be released in February with expanded benefit packages, and related support and navigation services will be included.

Judith F. shared that the DeLuca Foundation funds the YMCA for the Community Health Worker (CHW) Model. YMCA Community Health Workers serve as a trusted community advocate and frontline grassroots public health liaisons who empower individual and community capacity by increasing health knowledge and self-sufficiency through outreach, community education, informal counseling, and social support with a culturally competent lens.

Members raised the need for Haitian, Spanish, and Portuguese-speaking navigators.

Cassandra B. suggested the need for a data system to see if we are duplicating services to the same families and to help find gaps.

Lisa B. presented the CMHW salary information to members. A copy will be shared with members via email.

Judith F. suggested that Unite Us, an organization that brings agencies together and has been successful in the Sarasota area, attend the next meeting to present to members about their platform.

Maria J. S. will invite Sue Gallaher, CSC's Chief Innovation Officer, to a future meeting to discuss lessons learned regarding the development of a comprehensive data system with members.

Explore Interest in forming a sub-committee to share provider performance.

Maria J. S. asked members if they were interested in restoring a subcommittee where they could share information about the services they fund and provider performance, discuss challenges, and develop solutions to address the challenges. Members agreed that it would be helpful but suggested that this discussion take place during the Funders Forum meeting.

Cassandra E. suggested that members create a collective list of programs that specifies where the funding is invested, how it covers the community's needs, and how well they are performing. They should also discuss best practices and steps that members can take to help those struggling to perform better.

Members suggested beginning the task by focusing on one area of service. Judith F. requested that members begin with the area of workforce next month.

It was suggested that members begin by providing their data around each focus area prior to the next Funders Forum meeting so that the data can be included on one spreadsheet for members to review. Maria J. S., Dion S., and Lisa B. will meet to discuss and devise the best way to move this request.

Moving forward this topic will be added to the Funders Forum meeting agenda.

Funders Forum Member Updates:

Community Foundation of Broward

Sheri B. G. thanked members for their letters of support which were included in their proposal to the Ounce of Prevention for the Florida Children's Initiative, which will harness the collective power of our community's resources to improve the living conditions and opportunities for children and families in the Pompano Beach / Blanche Ely area. The application will go to the Florida Legislature in March. In the interim, the Community Foundation will be partnering with CSC around Asset Based Community Development (ABCD) training so that there is consistent momentum with this work while they await the approval for the award, which is expected to be in July.

CareerSource

Carol H. announced that CareerSource received a \$785,000 noncustodial parent grant award to help non-custodial parents who are behind in child support payments or who may be struggling to make them. A flyer with more information will be sent to members.

Next Funders Forum Meeting

The next meeting will be held virtually on Friday, November 1, 2024, from 2:00 p.m. to 4:00 p.m. Members should contact Radoika Pilarte at rpilarte@cscbroward.org to include any additional agenda items.

The meeting was adjourned at 3:40 p.m.

TAB H



Human Services Department

COMMUNITY PARTNERSHIPS DIVISION / Children's Services Administration

115 S Andrews Avenue, Room A370 • Fort Lauderdale, Florida 33301 • 954-357-6202 • FAX 954-357-8204

Broward County Board of County Commissioners
Children's Services Board
Draft Meeting Minutes – August 16, 2024
9:00 am – 11:00 A.M.

1. Call to Order

Evan Goldman called the meeting to order at 9:03 A.M. and welcomed all Board Members.

2. Roll Call

Jarvis Brunson called the roll.

A quorum was established with Evan Goldman, Monica King, Jarvis Brunson, Cara Malave, Joel Smith, Daniel Schevis, Elida Segrera, Sarah Gillespie Cummings, Cassandra Burrell, Veda Hudge, and Traci Schweitzer present. Maria Juarez Stouffer and Malena Mendez via TEAMS.

Members absent: Brenda Fam, Teves Bush, Burton Miller, and Commissioner Michael Udine.

Staff Members in attendance: Efreem Crenshaw, Community Partnerships Division (CPD) Director Cassandra Evans, (CPD) Assistant Director, Dr. Tiffany Hill-Howard, Children's Services Administrator (CSA), Sterling Parrish, Contract Grant Administrator Sr. (CSA), and Ronald Honick, Assistant County Attorney present.

Motion: To approve the CSB June 21 and July 19 minutes.

First: Joel Smith

Second: Elida Segrera

Declaration of Conflict: None

Discussion: None

Result: Passed

3. Chair Report

Evan Goldman gave an overview of the meeting discussion to address the role of a Children's Services Board (CSB) member and what a Board member needs from Children's Services Administration professionals to accomplish their goals. Chairman Goldman provided Dr. Tiffany Hill-Howard with the floor to give the Children's Services Section Report before the board members engaged in a discussion about their role on the CSB.

4. Section Report

Monitoring

Broward County Board of County Commissioners

• Mark D. Bogen • Lamar P. Fisher • Beam Furr • Steve Geller • Robert McKinzie • Nan H. Rich • Hazelle P. Rogers • Tim Ryan • Michael Udine
www.broward.org

Dr. Hill-Howard gave an update that all 30 providers had monitorings conducted and the Section is working on finalizing monitoring reports with all reports scheduled to be submitted to providers no later than the first week of September.

A kudos was also given to the Section team for improving visibility among providers and providing increased technical assistance resulting in all providers meeting the threshold for outcomes and not receiving a 3% penalty.

Utilization

Sterling Parrish, CGA Sr. provided an update on the Section's utilization through May 2024. Discussion was had about the graphs for Board members to understand the mid-year adjustments that providers received, and that the utilization of funds does not reflect the impact of the services and the gaps in services due to changes in provider program service delivery.

5. Chair Report

Discussion was had about the historical role of a CSB member and the purpose of a CSB member today is to provide guidance to CSA staff on unmet community needs, promote CSA programs and services within individual areas of influence and broader community, partner with CSA staff to deliver technical assistance to underperforming funded providers, and work cooperatively with other local funders to address the needs of children and families that are outside the service areas funded by CSA.

Discussion was had about the CSB charter that the CSB is tasked with the needs of children's services by using data to make an informed plan to provide services to the children and their families of Broward county.

Staff shared the unique position of the CSB members to advocate for needs of children and their families to their respective commissioner as an appointed board member and as a collective front to the Board of County Commissioners and County Administration.

Discussion was had about is needed from CSA staff by the CSB to accomplish the goals and objectives of the CSB and assist CSA. There was a collective consensus that CSB members want to be better informed on funded agencies such as monthly utilization by programs with simple explanations for over or under utilization.

RFP Update

Attorney Ronald Honick was asked the legal ramifications of the CSB being a part of the cone of silence during the RFP review process and allowed information regarding specific providers.

6. Committee Chair Reports

None

7. Liaison Reports

Veda Hudge: The School Board of Broward County was rated as an A school grade district. Additionally, a Wellness Center is having a grand opening at McNicol Middle School. The district is looking at other community-based schools and partners to host Wellness Center for medical and mental health services. A new job description of school counselors was taken before the board so that school counselors are providing counseling services. There is a Suicide policy that will be coming to the board. The district is looking to continuing working with Broward County to get non-police transportation for youth who are Baker-Acted. Veda Hudge will also be transitioning from the CSB with her confirmation as within a new role outside of the Student Services office in the school district.

Elida Segrera: BBHC received a cut in funding of approximately \$13 million dollars.

8. New Business

None.

9. Old Business

None.

10. Public Comment

None.

11. Good of the Order

None.

12. Adjournment

Motion: To adjourn the CSB meeting at 11:17 A.M.

First: Monica King

Second: Elida Segrera

Declaration of Conflict: None

Discussion: None

Result: Passed

The next Children's Services Board Meeting is October 18, 2024.

These minutes were approved at the Children's Services Board Meeting dated September 20, 2024, as certified by:

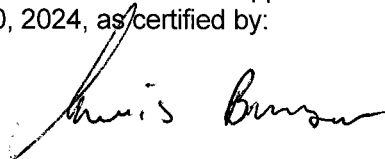

Jarvis Brunson
Children's Services Board Secretary



Children's Services Council

of Broward County

Our Focus is Our Children.

COMMUNITY IMPACT



**CHILDREN'S SERVICES COUNCIL
OF BROWARD COUNTY
MEMBERS:**

*Jeffrey S. Wood, Chair
Governor Appointee*

*Beam Furr, Vice Chair
Broward County Commission*

*Dr. Christine Thompson, Secretary
Governor Appointee*

*Alyssa Foganholi
Governor Appointee*

*Debra Hixon
Board Member
Broward County Public Schools*

*Dr. Howard Hepburn
Superintendent
Broward County Public Schools*

*Julia Musella
Governor Appointee*

*Robert Shea
Child Protection Director,
Southeast & Southern Regions
Department of Children & Families*

*Dr. Paula Thaqi
Director
Broward County Health Dept.*

*Honorable Francis Viamontes
Judicial Member*

*Vacant
Governor Appointee*

STAFF

*Cindy J. Arenberg Seltzer
President/CEO*

LEGAL COUNSEL

*John Milledge
Garry Johnson*

September 10, 2024

Mr. Kirk Brown, CEO
HANDY, Inc.
1717 North Andrews Ave.
Fort Lauderdale, FL 33311

Dear Mr. Brown:

The Children's Services Council of Broward County affirms our commitment to support the Community Partnership School initiative at Boyd Anderson High School. We are enthusiastic about joining this collaborative effort to enhance the educational and support services available to children and families in our community.

The Children's Service Council of Broward County is dedicated to improving the lives of children and families through comprehensive services and community-based solutions.

CSC supports the successful planning, implementation, and sustainability of the Community Partnership School, ensuring that it meets the diverse needs of its students and their families.

We are excited about the potential impact of this partnership and are committed to working closely with HANDY, Inc. and other core partners to achieve our shared goals. Please feel free to reach out if you have any questions or if there are specific ways we can further support this important initiative.

Thank you for your leadership and dedication to this project. We look forward to a successful collaboration.

Sincerely,

Cindy Arenberg Seltzer
Cindy Arenberg Seltzer, M.P.A., J.D.
President/CEO



Conference on Children's Literature



The 2024 Broward County Library (BCL) Annual Conference on Children’s Literature (COCL) will take place on Friday, September 20, 2024, at the African American Research Library and Cultural Center.

The overall goal of the conference is to highlight how community educators, parents, and caregivers can use children’s literature and other free library resources to enhance a student’s overall education.

September is often seen as the time of year to start fresh with new educational goals. This professional development event provides an opportunity to showcase information and resources that will help our community’s key stakeholders in children’s education to support, motivate, and encourage students as they embark on a new school year and has done so since 1987.

Each year, COCL attendees learn about the many print, online, and digital resources the library has to offer that will help children succeed. They will also hear presentations by award-winning authors and illustrators, making direct connections between the author and illustrator’s work and kindergarten readiness, grade level reading, and other components of

student success. Interactive sessions will be offered, allowing attendees to develop additional literacy education skills and apply them to their individual teaching circumstances.

This year's COCL is scheduled for Friday, September 20, 2024 at the African American Research Library and Cultural Center. Learn more about the amazing guest speaks and register by clicking [here](#)!

The 2024 Conference on Children's Literature is generously funded by the Broward Public Library Foundation and Children's Services Council of Broward. This program is presented through collaborations and partnerships with Broward Reads: The Campaign for Grade-Level Reading, Jumpstart for Young Children and Miami Book Fair. Books will be available for sale through Conference on Children's Literature book provider Books & Books.

To stay tuned for updates on this year's event, follow [@browardcountylibrary](#) and [@bplfoundation](#) on Facebook, Twitter, and Instagram or contact the Main Library at 954-357-7444.



Conference on Children's Literature

The Broward County Library's 2024 Conference on Children's Literature is an all-day event full of excellent and engaging creators. Register now, lunch will be served while supplies last.

The 2024 Conference is free to attend and open to educators of all kinds - librarians, teachers, and parents. The Conference will provide professional development, research and innovation in children's literature and support networking, collaboration and contribute to a national dialogue. Please register- a complimentary light lunch is included and you may win signed copies of some the featured titles!

[IF you can't make it in person JOIN US ONLINE!](#)

8:30- 9:00 AM Attendee Check-In and Complimentary Coffee

9:00 AM Conference Begins

9:05 AM - Creating Community Around Early Literacy in Broward County: Celebrating 10 Years of Broward Read for the Record

This panel presentation will discuss how Broward County works across agencies and departments to bring a large scale reading and distribution event to over 40,000 children each year. Our conversation will include information about the featured 2024 Jumpstart Read for the Record book, *Piper Chen Sings*. Panel members include: Maris Pasquale Doran, co-author of *Piper Chen Sings*, Crystal Rountree, CEO of Jumpstart, Cindy Arenberg Seltzer, CEO of Children's Services Council of Broward County and Dr. Lori Canning, Family and Community Engagement (FACE) from Broward County Public Schools.

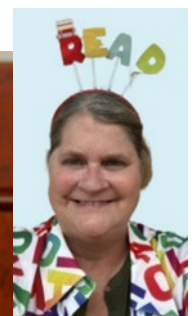
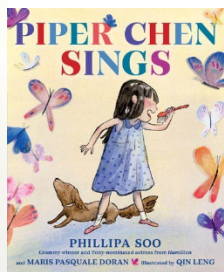

10:30 AM - Author Keynote with Johnnie Christmas, 2024 Ashley Bryan Art Series Featured Illustrator

Join acclaimed illustrator and graphic novelist Johnnie Christmas for an inspiring keynote talk. Known for his work on the award-winning graphic novel *Swim Team*, Johnnie will share his journey from aspiring artist to New York Times bestselling author. He will discuss the creative process behind his most celebrated works, including the challenges and triumphs of bringing diverse characters and stories to life.



12 PM - Lunchtime Author Chat with Katherine Applegate and Gennifer Choldenko

Join us for an engaging lunchtime chat with award-winning authors Katherine Applegate and Gennifer Choldenko as they discuss their collaborative series, *Dogtown*. They will discuss their creative process, the inspiration behind their heartwarming stories, and the real-life experiences that shaped their characters and plots. Authors Katherine Applegate and Gennifer Choldenko courtesy of Books & Books.



Books & Books

1:15 PM - Conversation with Sika Dagbovie Mullins and Raj Tawney

New York Times essayist, Raj Tawney, delivers a gripping story of a multi-ethnic American boy who forges a complex friendship with a Pakistani immigrant in the wake of 9/11. Based on the author's personal life experiences, an insightful middle-grade novel from a fresh voice in children's fiction that will be felt long after the last page.



2:15 PM - Creating a Culture of Reading through a discussion with 2024 Sunshine State Reader's Award Books Authors (In- Person and Online Panel)

This author panel will discuss reading motivation and reader's advisory through the use of state reading lists and the author's point of view.

In Person Moderator and Panel Authors: Diana Haneski, Library Media Specialist, Marjory Stoneman Douglas High School, Kerry O'Malley Cerra, author of *Hear Me* (SSYRA Grades 6-8); Natalia

Sylvester, author of *Breathe and Count Back from Ten* (Florida Teen Reads); and Betty Culley (presenting online), author of *The Name She Gave Me*.



Online Panel Authors: Mitali Banerjee Ruths (SSYRA Jr.- presenting online), co-author of *Awesome Orange Birthday*; Carmen Agra Deedy (SSYRA Jr.- presenting online), author of *Carina Felina* and Betty Culley (presenting online), author of *The Name She Gave Me*.

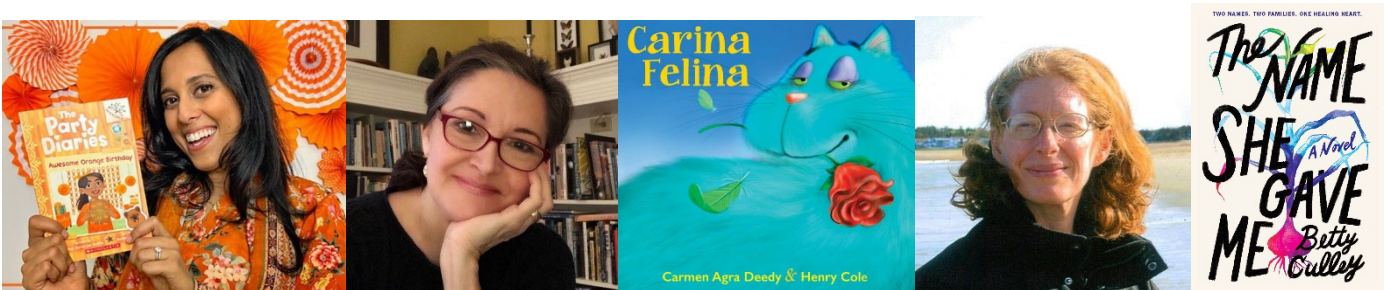

3:30 PM - 2024 Miami Book Fair Featured Online Author: Robin Ha



4:00 PM - 2024 Miami Book Fair Featured Online Author: Alexis Castellanos



Featured Authors and Presenters (In Order of Sessions)

[Maris Pasquale Doran](#), LCSW has always loved listening to and learning from people’s personal narratives and has evolved her career in social work to include writing and creating her own

characters and stories. She continues to work as a private psychotherapist and is an adjunct lecturer at Columbia University's School of Social Work. She lives in Maplewood, NJ with her husband and two young children. Reading to them is always her favorite part of the day.

[Crystal Rountree](#) joined Jumpstart as its new Chief Executive Officer in January 2024. She most recently served as the Chief Revenue and Development Officer at Teach For America (TFA) where she served on staff since 2005. As Chief Revenue and Development Officer Crystal was responsible for leading the team that grew, strengthened, and diversified TFA's philanthropic partnerships and revenue pathways to optimize and maximize contributions to TFA's impact.

[Cindy Arenberg Seltzer](#) has played a pivotal role as the inaugural President/CEO of the Children's Services Council of Broward County since the voters authorized it in September 2000 and reauthorized it in 2014. Her leadership has been instrumental in shaping the organization's mission and guiding its development toward substantially impacting the lives of children and families. She has been honored for her leadership and commitment to excellence on numerous occasions throughout her career, including, most recently, induction into the Broward County Women's Hall of Fame, honored as a Neighborhood Hero by Neighbors 4 Neighbors, recognition of CSC as a Sun-Sentinel Top Workplace in 2023 and 2024, and receiving the Leadership Award in the Small Employer Group from the Sun-Sentinel Top Work Places 2024.

Dr. Lori Canning is the Executive Director of [Family and Community Engagement \(FACE\)](#) at Broward County Public Schools where she leads the programs and partnerships at Gulfstream Early Learning Center and the departments of Family and Community Engagement. Additionally, she is a leader in the Broward Reads Campaign and Serves on the Board of the Healthy Start Coalition.

[Johnnie Christmas](#) is a #1 New York Times Best Selling graphic novelist. His 2022 middle grade graphic novel debut *Swim Team* earned a spot on the National Book Awards longlist, a Coretta Scott King Award Illustrator Honor and a Harvey Awards nomination. A graduate of the Pratt Institute in Brooklyn, NY, earning a BFA in Communication Design/Illustration. Johnnie makes Vancouver, BC his home.

[Katherine Applegate](#) is the New York Times–bestselling author of *Wishtree*, *Crenshaw*, *Willodeen*, and *Home of the Brave*, as well as *The One and Only Ivan*, winner of the Newbery Medal, and its sequel *The One and Only Bob*. She lives in Southern California with her family.

[Gennifer Choldenko's](#) best known *Tales from Alcatraz* series, has been called “A cornerstone series in contemporary children's literature.” *Al Capone Does My Shirts*—the first book in the series—was a Newbery Honor Book and the recipient of twenty other awards. All four books in the series were Junior Library Guild selections and garnered many starred reviews. Gennifer lives in the San Francisco Bay area with her loyal husband and naughty dog.

[Sika Dagbovie-Mullins](#) is a professor in the Department of English at Florida Atlantic University where she specializes in twentieth and twenty-first century African American literature. She is author of *Crossing B(l)ack: Mixed Race Identity in Modern American Fiction and Culture* (University of Tennessee Press, 2013) and co-editor of *Mixed-Race Superheroes* (Rutgers University Press, 2021) which examines representations of racial mixedness and the idea of the superhero. Her current project, *Black Place in Florida*, is a co-edited anthology that will explore how black Floridians, with

origins from across the diaspora, claim space or take up place in the state. She serves on the editorial board of the University Press of Florida and the Journal of Popular Culture.

[Raj Tawney](#) is a writer and journalist whose work largely reflects his mixed-race upbringing in suburban Long Island, NY. Born to an Indian, Puerto Rican, and Italian American family, Tawney has explored his identity through personal essays published in The New York Times, The Washington Post, USA Today, and other outlets throughout the country. His debut memoir *Colorful Palate: A Flavorful Journey Through a Mixed American Experience* (Fordham University Press) was published in 2023 to much acclaim. His upcoming book *All Mixed Up* will release in October 2024. He is based in Miami, Florida.

[Diana Haneski](#), is known for her enthusiasm, energy, and willingness to help students and teachers find the books they want to read and the information and resources they need. As a library teacher for 26 years, Haneski holds National Board Certification in Library Media, a Master of Science in Library Studies, and a Bachelor of Arts in Communication Speech and Theatre. Diana Haneski has presented at conferences and has trained her colleagues in Broward for two decades. Most recently, Diana along with MSD therapy dog River, focus on mindfulness and self-care not only in Broward but throughout Florida and nationwide. Diana is a [I Love My Librarian Award 2024 Honoree](#).

[Kerry O'Malley Cerra](#) is an award-winning author of middle grade books. A deaf author herself (who now hears with the help of one cochlear implant), she's passionate about books that depict d/Deaf and/or hearing loss experiences for children. Kerry, a former high school media specialist and social studies teacher, lives in South Florida with her husband and two poorly behaved rescue dogs.

Born in Lima, Peru, [Natalia Sylvester](#) is an award-winning author of books for children, teens, and young adults, among them *Running* (2020) and *Everyone Knows You Go Home* (2018), which won the International Latino Book Award. Her latest YA novel, *Breathe and Count Back from Ten*, was named a Pura Belpré honor book and Schneider Family honor book in 2023 by the American Library Association, and is a 2024-2025 Florida Teens Read title. Natalia's first picture book, *A Maleta Full of Treasures* (illustrated by Juana Medina) is a Junior Library Guild Selection for both its English and Spanish versions.

[Mitali Banerjee Ruths](#) (presenting online), grew up in Houston, TX and dreamed of becoming an astronaut someday. She writes early in the morning on paper and types late at night on her computer. She loves telling stories, eating cookies, knitting sweaters, and going for walks in beautiful landscapes. She lives in Canada with her husband, three kids, and their dog Tux. One day, she would like to orbit the earth and knit in zero gravity with floating yarn while watching a sunrise every 90 minutes.

[Carmen Agra Deedy](#) (presenting online), is an award-winning author of fifteen books for young readers. Her personal stories first appeared on NPR's All Things Considered. Funny, insightful, and frequently irreverent, Deedy's narratives are culled from her childhood as a Cuban refugee in Decatur, GA. She is host of the Emmy-winning children's program, *Love That Book!*

[Betty Culley](#) (presenting online) is the award-winning author of young adult and middle grade novels. She's also an RN who worked as an obstetrics nurse and as a pediatric home hospice nurse. She lives in central Maine, where the rivers run through the small towns.

[Robin Ha](#) (presenting online) is the award-winning author/illustrator of the graphic novel memoir *Almost American Girl*. At fourteen she moved to the United States from Seoul, Korea. Her comics and illustrations have appeared in various publications, including the Washington Post and the Los Angeles Times, as well as in anthologies highlighting Asian American culture, including *Rise: A Pop History of Asian America from the Nineties to Now*, *New Frontiers: The Many Worlds of George Takei*, and *Shattered: The Asian American Comics Anthology (Secret Identities)*. She is also the author of the best-selling comic recipe book *Cook Korean!: A Comic Book With Recipes*. Her new graphic novel, *The Fox Maidens* is published by Balzer and Bray in February 2024.

[Alexis Castellanos](#) (presenting online) is the author of *Guava & Grudges* (Bloomsbury) and *Isla to Island* (Simon & Schuster), an Eisner-nominated and award-winning graphic novel. Born in Miami, FL, she studied theatre design and technology in college and landed in New York City after graduation working as a scenic artist before transitioning into publishing as a graphic designer. When she's not working she can be found tackling a new sewing project, playing D&D, or cooking up a storm. For now she's calling Los Angeles home, where she lives with her partner and two spoiled cats.

The 2024 Conference on Children's Literature is generously funded by the [Broward Public Library Foundation](#), [Children's Services Council of Broward](#) and [Florida Virtual School](#). The Ashley Bryan Art Series is generously funded by the [Helios Education Foundation](#). Natalia Sylvester is generously funded by [Reforma de Florida](#).



This program is presented through collaborations and partnerships with [Broward Reads: The Campaign for Grade-Level Reading](#); [Jumpstart for Young Children](#), [Miami Book Fair](#) and [Books & Books](#). Books will be available for sale through Conference on Children's Literature book provider [Books & Books](#).



About the African American Research Library and Cultural Center

The Broward County African American Research Library and Cultural Center (AARLCC) is located in the Sistrunk community, one of the oldest historically Black communities named for one of Fort Lauderdale's first Black physicians. Opening to the public on October 26, 2002, AARLCC became the third public library of its kind in the United States dedicated to the study of Black history and culture. The 60,000 square-foot Center serves as a repository of materials related to the local, national, and international voices of the African diaspora with more than 85,000 books, manuscripts, artifacts, framed art, print, photography, audiovisual, and documents held in our Adult Services Section and Special Collections. The Youth Services Section features a special collection of Coretta Scott King Award books and the Ashley Bryan Art Collection from illustrators of African Descent. AARLCC also features a 5,000 sq. ft. museum, a 300-seat state-of-the-art theatre, and a Computer Training Center.

AGE GROUP: | [New Adults](#) | [Everyone](#) | [Adults](#) |

EVENT TYPE: | [Workshop](#) | [Discussion/Lecture](#) | [Books](#) | [Author Events](#) |

TAGS: | [Trending Topics](#) | [Hispanic Heritage](#) | [Back to School](#) |



**CHILDREN'S SERVICES COUNCIL
OF BROWARD COUNTY
MEMBERS:**

*Jeffrey S. Wood, Chair
Governor Appointee*

*Beam Furr, Vice Chair
Broward County Commission*

*Dr. Christine Thompson, Secretary
Governor Appointee*

*Alyssa Foganholi
Governor Appointee*

*Debra Hixon
Board Member
Broward County Public Schools*

*Dr. Howard Hepburn
Superintendent
Broward County Public Schools*

*Julia Musella
Governor Appointee*

*Robert Shea
Child Protection Director,
Southeast & Southern Regions
Department of Children & Families*

*Dr. Paula Thaqi
Director
Broward County Health Dept.*

*Honorable Francis Viamontes
Judicial Member*

*Vacant
Governor Appointee*

STAFF

*Cindy J. Arenberg Seltzer
President/CEO*

LEGAL COUNSEL

John Milledge

Garry Johnson

September 23, 2024

Sheri Brown Grosvenor, MSHRD
Vice President, Community Impact
Community Foundation of Broward
910 East Las Olas Blvd., Suite 200
Fort Lauderdale, FL 33301

Dear Ms. Grosvenor,

On behalf of the Children's Services Council (CSC) of Broward County, I am pleased to offer our support for the Community Foundation of Broward's application to secure the Florida Children's Initiative (FCI) designation for the Blanche Ely and Sanders Park neighborhoods through the Pompano RYZE (Resilient Youth with Zeal to Excel) Exit 36 Initiative. As an active member of the FCI Pompano Planning Committee, CSC has been deeply involved in the development and strategic direction of this transformative initiative, and we are committed to seeing it bring meaningful change to the children and families of Pompano Beach. The Blanche Ely and Sanders Park neighborhoods meet the criteria outlined in Florida Statute 409.147, which identifies severely disadvantaged areas where infrastructure and opportunities are insufficient to meet the needs of children and families.

The CSC is dedicated to ensuring that all children in our community have access to the opportunities and resources they need to succeed. Our mission to fund and support programs that provide education, school nurses, child development, Asset Based Community Development to engage residents, and child/family support services closely aligns with the goals of the Pompano RYZE Exit 36 Initiative. This initiative addresses the critical challenges of educational disparities, economic instability, and social inequities by

creating a cradle-to-career support system that empowers children, youth, and families to provide direct engagement and governance in funding decisions to support these historically underserved neighborhoods.

In our role within Broward County, CSC provides funding and oversight for a wide array of programs to improve the lives of children and families, including a focus on those living in vulnerable communities like Blanche Ely and Sanders Park. We understand the complexities of breaking the cycle of poverty, and we are committed to leveraging our expertise, resources, and partnerships to ensure the success of the Pompano RYZE Initiative. By addressing the social determinants of health, including access to education, stable housing, healthcare, and economic opportunities, we believe this initiative will provide a pathway to long-term success for the residents of these neighborhoods.

CSC is committed to working alongside the Community Foundation of Broward and other key partners to ensure that the Pompano RYZE Exit 36 Initiative delivers impactful results with the Blanche Ely and Sanders Park communities. We will continue to serve as an active partner providing funding to existing CSC programs that serve children and families in the RYZE Exit 36 communities. Our goal is to ensure that every child in Pompano Beach has the opportunity to thrive, and we are confident that this initiative will create sustainable change in these neighborhoods.

We are proud to be a part of this process. We are excited about the Pompano RYZE Exit 36 Initiative's future impact on the children and families of Pompano Beach. We look forward to our continued collaboration and are committed to supporting this effort as it moves forward.

Sincerely,



Cindy Arenberg Seltzer, M.P.A., J.D.
President & CEO



**CHILDREN'S SERVICES
COUNCIL OF BROWARD
COUNTY MEMBERS:**

- Jeffrey S. Wood, Chair
Governor Appointee*
- Beam Furr, Vice Chair
Broward County Commission*
- Dr. Christine Thompson,
Secretary
Governor Appointee*
- Alyssa Foganholi
Governor Appointee*
- Debra Hixon
Board Member
Broward County Public
Schools*
- Dr. Howard Hepburn
Superintendent
Broward County Public
Schools*
- Julia Musella
Governor Appointee*
- Robert Shea
Child Protection Director,
Southeast & Southern
Regions
Department of Children &
Families*
- Dr. Paula Thaqi
Director
Broward County Health Dept.*
- Honorable Francis Viamontes
Judicial Member*
- Vacant
Governor Appointee*

STAFF

*Cindy J. Arenberg Seltzer
President/CEO*

LEGAL COUNSEL

*John Milledge
Garry Johnson*

October 1, 2024

Florida Department of State
Division of Arts & Culture
R.A. Gray Building
500 South Bronough Street
Tallahassee, FL 32399-0250

Re: 2025-2026 Cultural Facilities Grant Application

To Whom It May Concern:

This letter is in support of the City of West Park's (Broward County, Florida) application for a 2025-2026 Division of Arts & Culture grant to be used towards the Construction of a Cultural Center at McTyre Park Phase I. The City currently lacks sufficient space for culturally diverse programs and events and would greatly benefit from a center that would attract youth and families, providing them with an outlet for artistic activities and self-expression in a safe space with a sense of community.

The Children's Services Council of Broward County (CSC) has partnered with the City of West Park over the years to provide programs and services that enhance children's lives and empower them to become responsible, productive adults who can have the opportunity to realize their full potential, hopes, and dreams. The **Cultural Center at McTyre Park Phase I** would allow for more diverse programming and activities, which would benefit the City's youth and contribute to a higher quality of life.

Please contact me if you have any questions or desire additional information concerning our support for the City of West Park's proposed Cultural Center at McTyre Park Phase I grant application.

Sincerely,

Cindy Arenberg Seltzer, M.P.A., J.D.
President & CEO

Honorees Announced for FLITE Center's Westin Fort Lauderdale Beach Resort Heroes Luncheon On November 1

By Community News Releases -October 2, 2024



WPLG Local 10's Eric Yutzy returns to host FLITE Center's seventh annual Westin Fort Lauderdale Beach Resort Heroes Luncheon on November 1. Photo courtesy of WPLG Local 10

FLITE Center, a nonprofit organization dedicated to guiding vulnerable youth and those transitioning out of foster care towards independence through housing, education, employment, and comprehensive care coordination, will host its seventh annual Westin Fort Lauderdale Beach Resort Heroes Luncheon on Friday, November 1, from 11 a.m. to 1:30 p.m. WPLG Local 10's Eric Yutzy returns to emcee the special event at the Westin Fort Lauderdale Beach Resort (321 N. Fort Lauderdale Beach Blvd. in Fort Lauderdale) that will kick off the organization's 15th anniversary celebration.

FLITE Center's Westin Fort Lauderdale Beach Resort Heroes Luncheon is a tribute to the organization's partners, funders, and frontline staff who support and dedicate their lives to impacting youth in South Florida's Transitional Independent Living (TIL) System of Care. Last year's sold-out luncheon for 500 underscored the South Florida's commitment to nurturing and developing skills for our most vulnerable youth.

“Last year, FLITE Center served 1,901 young individuals, a bold number which could not have been accomplished without the support of our community champions – extraordinary individuals, companies, and partners who share our mission to paving a brighter future for vulnerable youth,” said Christine Frederick, CEO of FLITE Center. “We are grateful for the generosity of our partners who have helped us grow and create safe spaces in Palm Beach County where we will continue to serve even more youth in our Transitional Independent Living (TIL) System of Care.”

This year’s honorees and their respective award categories are:

Albert & Beatriz Miniaci Lifetime Heroes Award – Marcia Barry Smith, MBS Consulting Advisors Inc. and Larry Rein, ChildNet

Community Champion Award – Jen Klaassens, Jen Klaassens Consulting; Walter H. Honaman, Esq., Legal Aid Service of Broward County; Covelli Enterprises/Panera

Gore Foundation You Matter Award – Paul Palank Memorial Foundation and Freddy Figgers Foundation

Memorial Healthcare System Collaborators of the Year – Florida Community Health Partners

Children’s Services Council TIL System of Care Hero Award – TD Charitable Foundation

TIL System of Care Impact Award – Cleveland Clinic Florida

TIL System of Care Unsung Heroes – Frontline staff from collaborating organizations in the TIL System of Care

UKG Ultimate Acts of Kindness – Eric Hill, AvevoRx; Arun Raghuvi, Jyotirmaya Yoga Kendra and The Florida Panthers Foundation

TIL System of Care Youth Heroes Award – Maranatha Solomon and Trevion “Comet” Johnson, two TIL youth who have displayed remarkable resilience and dedication toward becoming self-sufficient

FLITE Center’s Westin Fort Lauderdale Beach Resort Heroes Luncheon is presented by title sponsor Westin Fort Lauderdale Beach Resort and sponsored by Amazon, BBX Capital, Seminole Casino Coconut Creek, Seminole Hard Rock Hotel & Casino Hollywood, Premier Aircraft, The Vegso Family Foundation, Transworld Business Advisors, Memorial Healthcare System, Ackerman, Grey Robinson, ChildNet, UKG, South Florida Business & Wealth/Lifestyle Media Group, GPR | Goodman Public Relations and Synovus Bank.

Tickets are \$100 per person (\$75 for government agency employees) and are available for purchase online at FLITECenter.org/Heroes24.

For more information or to secure a sponsorship, please contact Bich-ly Ludwig, CNP, FLITE Center's vice president of development, at (954) 530-4686 or bich-ly@flitecenter.org.

MONTHLY COUNCIL MEETING ATTENDANCE
October 2023–September 2024 (FY 23/24)

Council Member	Oct'23	Nov'23*	Dec'23	Jan'24	Feb'24	Mar'24	Apr'24	May'24	Jun'24	Jul'24	Aug'24	TRIM I	Sep'24	TRIM II
Michael Davis***	P	A	N/A	A	N/A	N/A	N/A	N/A	N/A	N/A	N/A	N/A	N/A	N/A
Cathy Donnelly*****	A	A	N/A	P	P	A	P	A	P	N/A	N/A	N/A	N/A	N/A
Alyssa Foganholi*****	N/A	N/A	N/A	N/A	N/A	N/A	N/A	N/A	N/A	N/A	P	P	P	P
Beam Furr	P	A	N/A	P	P	A	P	P	P	N/A	P	P	P	P
Howard Hepburn*****	N/A	N/A	N/A	N/A	N/A	N/A	A	A	P	N/A	A	P	P	P
Debra Hixon**	N/A	P	N/A	P	P	P	P	P	P	N/A	A	P	A	A
David H. Kenton	P	P	N/A	P	P	P	P	P	P	N/A	P	N/A	N/A	N/A
Peter B. Licata*****	P	A	N/A	A	P	A	N/A	N/A	N/A	N/A	N/A	N/A	N/A	N/A
Dennis Miles****	P	P	N/A	P	A	N/A	N/A	N/A	N/A	N/A	N/A	N/A	N/A	N/A
Julia Musella*****	N/A	N/A	N/A	N/A	N/A	N/A	N/A	N/A	N/A	N/A	P	P	P	P
Robert Shea****	N/A	N/A	N/A	N/A	N/A	P	P	P	P	N/A	P	A	A	Virtual
Paula Thaqi	A	P	N/A	P	Virtual	P	Virtual	P	P	N/A	P	A	P	P
Christine Thompson*****	N/A	N/A	N/A	N/A	N/A	N/A	N/A	N/A	N/A	N/A	P	P	A	A
Jeffrey S. Wood	Virtual	P	N/A	Virtual	P	A	P	P	P	N/A	P	P	P	P
Francis Viamontes***	N/A	N/A	N/A	N/A	P	P	P	P	P	N/A	A	A	P	P
Allen Zeman**	A	N/A	N/A	N/A	N/A	N/A	N/A	N/A	N/A	N/A	N/A	N/A	N/A	N/A

* The Nov 16, 2023, monthly meeting was postponed to December 8, 2023, due to flooding.

** The School Board’s annual organizational meeting was held Nov 14, 2023, and Debra Hixon was appointed as the BCSB representative to the CSC. She replaces School Board Member Zeman.

*** Judge Davis, who no longer presides over juvenile cases, was replaced by Judge Francis Viamontes on February 1, 2024.

**** Dennis Miles appointed Robert Shea as the DCF representative on March 21, 2024.

*****Howard Hepburn was appointed Superintendent on April 16, 2024, two days before CSC meeting, replacing Peter Licata.

*****The Governor appointed Alyssa Foganholi, Julia Musella, and Christine Thompson on 9/9/24. Ms. Donnelly did not reapply for a new term.